

ESECUZIONI SPECIALI
SPECIAL EXECUTIONS
SONDERAUSFÜHRUNGEN
EXECUTIONS SPECIALES

Caratteristiche tecniche I

- Intercambiabilità:
(PGR) serie 5000 Gromelle
(PGV) mercato giapponese
(PSS-PSV) serie 4000 Parker
(PNZ) serie PBR
- Occlusione: valvola o sfera
- Aggancio: sfere radiali
- Materiale: acciaio o acciaio inossidabile (PGRX)
- Finitura: Zn-Fe (Cr III)
- Filettature: BSP o NPT
- Guarnizioni standard: NBR o FKM (PGRX)
- Temperatura d'esercizio:
-25 °C +100 °C / -25 °C +200 °C (PGRX)
- Guarnizioni opzionali: FKM, EPDM o altro
- Pressioni di esercizio: 200-300 bar
- Connessione in pressione: non consentita

Technical data E

- Interchange:
(PGR) Gromelle 5000 series
(PGV) Japanese market
(PSS-PSV) Parker 4000 series
(PNZ) PBR series
- Occlusion: poppet or ball
- Locking: radial balls
- Material: steel or stainless steel (PGRX)
- Finishing: Zn-Fe (Cr III)
- Threads: BSP or NPT
- Standard seals: NBR or FKM (PGRX)
- Working temperature:
-25 °C +100°C / -25 °C +200 °C (PGRX)
- Optional seals: FKM, EPDM or more
- Working pressure: 200-300 bar
- Connection under pressure: not allowed

Technische Merkmale D

- Austauschbarkeit:
(PGR) Gromelle 5000 Serie
(PGV) japanischer Markt
(PSS-PSV) Parker 4000 Serie
(PNZ) PBR Serie
- Verschluss: ventil oder kugel
- Kupplung: Radial Kugeln
- Werkstoff: Stahl oder Edelstahl (PGRX)
- Ausführung: Zn-Fe (Cr III)
- Gewinde: BSP oder NPT
- Standard-Dichtungen: NBR oder FKM (PGRX)
- Betriebstemperatur:
-25 °C +100 °C / -25 °C +200 °C (PGRX)
- Dichtungen nach Wahl: FKM, EPDM, usw.
- Betriebsdruck: 200-300 bar
- Kuppeln unter Druck: nicht möglich

Caracteristiques techniques F

- Intercambiabilità:
(PGR) série 5000 Gromelle
(PGV) marché japonais
(PSS-PSV) série 4000 Parker
(PNZ) série PBR
- Obturation: clapet ou bille
- Accrochage: billes radiales
- Matériel: acier ou acier inoxydable (PGRX)
- Traitement: Zn-Fe (Cr III)
- Taraudage: BSP ou NPT
- Joints standard: NBR ou FKM (PGRX)
- Température de service:
-25 °C +100 °C / -25 °C +200 °C (PGRX)
- Joints facultatifs: FKM, EPDM, ect.
- Pression de service: 200-300 bar
- Connexion sous pression: pas possible

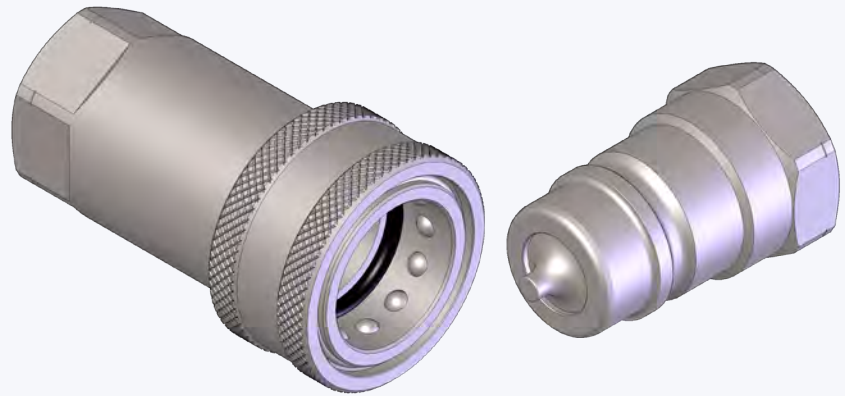

Nominal size	Max working pressure	Rated flow	Max flow rate	Min burst pressure			Fluid spillage				
				Male	Female	Coupled					
DNP	BG	ISO	mm	MPa	l/min	l/min	MPa	MPa	MPa	cc	
PGR1	25	5	25	16.6	27	104	210	120	120	110	13
PGRX	25	5	25	16.6	20	104	210	80	100	75	13
PGV1	25	5	25	17.3	25	113	225	120	100	100	15
PSS1	20	4	19	12	22	58	100	93	88	110	4.6
PSV1	20	4	19	12.3	25	106	220	100	140	130	11
PNZ1	25	5	25	17.3	30	200	400	140	130	130	16

1 MPa = 145.04 psi • 1 l = 0.264 gal

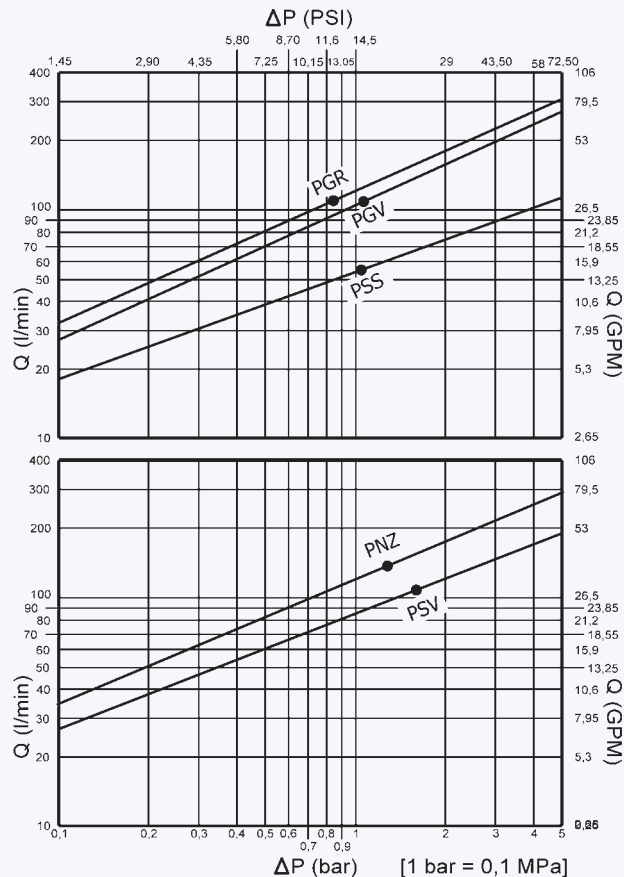

PGR1 DN25 - BG 5 - ISO 25

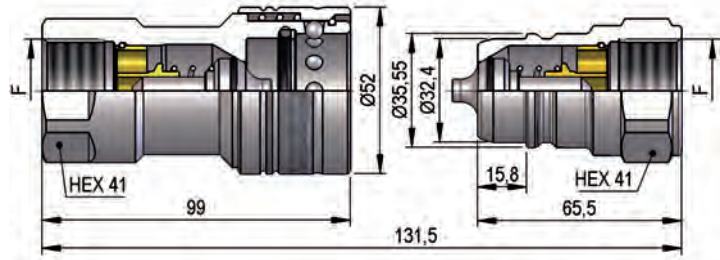

F	STANDARD	FEMMINA - FEMALE - MUFFE - FEMELLE			MASCIO - MALE - STECKER - MALE		
		COD. F	Weight (g)	Packaging (pcs.)	COD. M	Weight (g)	Packaging (pcs.)
BSP 1"	DIN 3852-2-X	PGR1.2525.002	712	20	PGR1.2525.003	296	30

PGRX DN25 - BG 5 - ISO 25

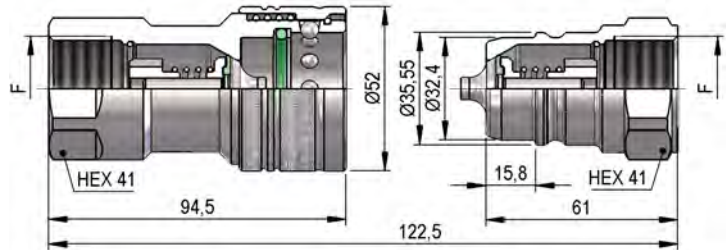

F	STANDARD	FEMMINA - FEMALE - MUFFE - FEMELLE			MASCIO - MALE - STECKER - MALE		
		COD. F	Weight (g)	Packaging (pcs.)	COD. M	Weight (g)	Packaging (pcs.)
BSP 1"	DIN 3852-2-X	PGRX.2525.002	672	20	PGRX.2525.003	255	30

PGV1 DN25 - BG 5 - ISO 25

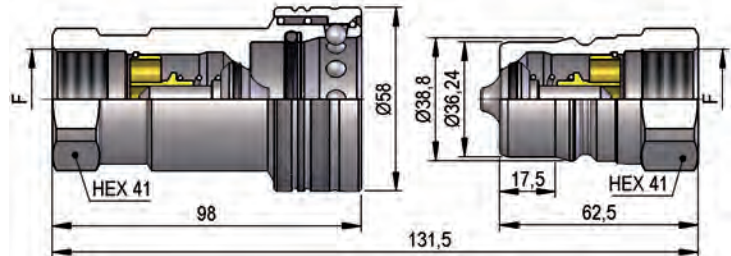

F	STANDARD	FEMMINA - FEMALE - MUFFE - FEMELLE			MASCIO - MALE - STECKER - MALE		
		COD. F	Weight (g)	Packaging (pcs.)	COD. M	Weight (g)	Packaging (pcs.)
BSP 1"	DIN 3852-2-X	PGV1.2525.002	745	18	PGV1.2525.003	326	30

PSS1 DN20 - BG 4 - ISO 19

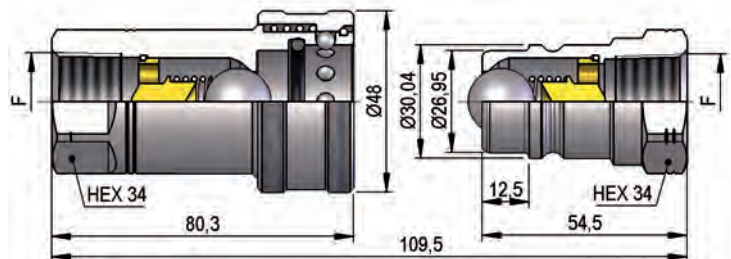

F	STANDARD	FEMMINA - FEMALE - MUFFE - FEMELLE			MASCIO - MALE - STECKER - MALE		
		COD. F	Weight (g)	Packaging (pcs.)	COD. M	Weight (g)	Packaging (pcs.)
NPT 3/4"	ANSI B1.20.3	PSS1.2019.012	506	28	PSS1.2019.013	180	45

PSV1 DN20 - BG 4 - ISO 19

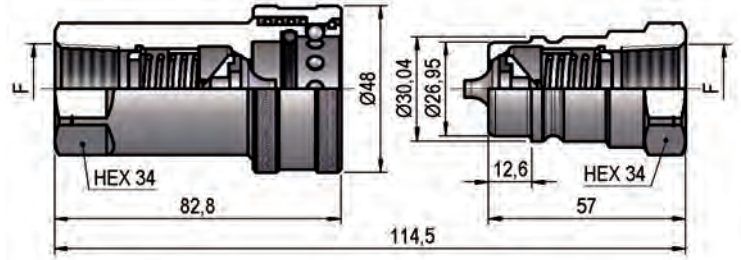

F	STANDARD	FEMMINA - FEMALE - MUFFE - FEMELLE			MASCHIO - MALE - STECKER - MALE		
		COD. F	Weight (g)	Packaging (pcs.)	COD. M	Weight (g)	Packaging (pcs.)
NPT 3/4"	ANSI B1.20.3	PSV1.2019.012	502	28	PSV1.2019.013	171	45

PNZ1 DN25 - BG 5 - ISO 25

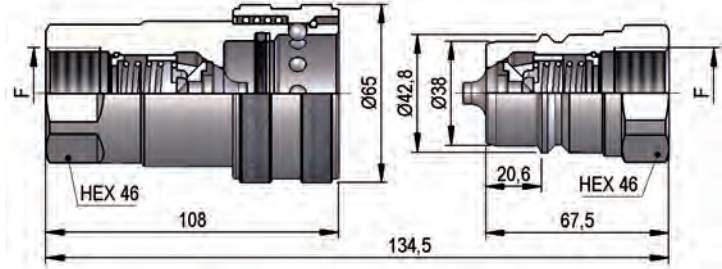

F	STANDARD	FEMMINA - FEMALE - MUFFE - FEMELLE			MASCHIO - MALE - STECKER - MALE		
		COD. F	Weight (g)	Packaging (pcs.)	COD. M	Weight (g)	Packaging (pcs.)
BSP 1"	DIN 3852-2-X	PNZ1.2525.002	1270	12	PNZ1.2525.003	459	24

ACCESSORI / ACCESSORIES / ZUBEHÖR / ACCESSOIRES

SPARE PARTS

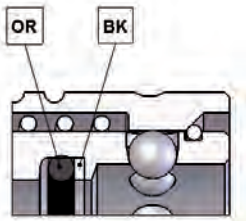

	NOMINAL SIZE			FEMALE GASKET	
	DNP	BG	ISO	OR (NBR*-FKM)	BK (PTFE)
PGR1	25	5	25	PGR.025.120	PGR.025.130
PGRX	25	5	25	PGR.025.120 V	PGR.025.130
PGV1	25	5	25	PGV.025.120	PGV.025.130
PSS1	20	4	19	PSS.019.120	-
PSV1	20	4	19	PSS.019.120	-
PNZ1	25	5	25	PBV.025.120	PNZ.025.130

*AL CODICE DELLA GUARNIZIONE IN NBR AGGIUNGERE 'E' PER EPDM O 'V' PER VITON

*TO THE NBR GASKET CODE ADD 'E' FOR EPDM OR 'V' FOR VITON

*ZU DER ARTIKELNR. DER NBR DICHTUNG GEBEN SIE 'E' FUER EPDM ODER 'V' FUER VITON AN

*AU CODE DU JOINT EN NBR JOINDRE 'E' POUR EPDM OU 'V' POUR VITON