

STANDARD

VALVOLA
POPPET
VENTIL
CLAPET

Caratteristiche tecniche I

- Intercambiabilità: con i principali produttori
- Occlusione: valvola
- Aggancio: sfere radiali
- Materiale: acciaio
- Finitura: Zn-Fe (Cr III)
- Filettature: BSP - NPT
- Guarnizioni standard: NBR
- Temperatura d'esercizio: -25 °C +100 °C
- Guarnizioni opzionali: FKM, FFKM, EPDM o altro
- Pressioni di esercizio: 100-400 bar
- Connessione in pressione: non consentita

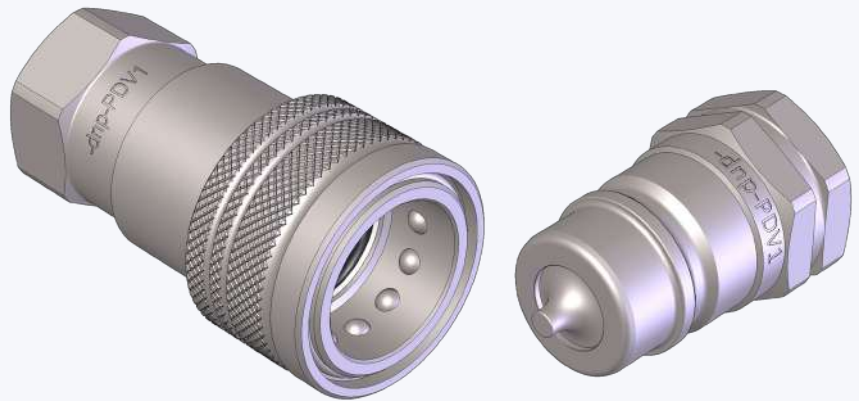

Technical data E

- Interchange: with the main producers
- Occlusion: poppet
- Locking: radial balls
- Material: steel
- Finishing: Zn-Fe (Cr III)
- Threads: BSP - NPT
- Standard seals: NBR
- Working temperature: -25 °C +100 °C
- Optional seals: FKM, FFKM, EPDM or more
- Working pressure: 100-400 bar
- Connection under pressure: not allowed

Nominal size				Max working pressure	Rated flow	Max flow rate	Min burst pressure			Fluid spillage
DNP	BG	ISO	mm				Male	Female	Coupled	
06	1	6.3	6.5	40	12	24	160	170	170	1
10	2	10	8.5	35	23	46	150	170	150	2.4
13	3	12.5	10.5	25	45	90	100	140	120	2.7
20	4	19	15.7	25	106	190	100	120	110	8.6
25	5	25	16.6	25	189	250	120	110	100	13
30	6	31.5	22.8	22	288	480	100	90	100	30
39	7	40	29.9	20	379	700	96	80	80	52
50	8	50	46.5	10	757	1000	40	40	40	90

1 MPa = 145.04 psi • 1 l = 0.264 gal

Technische Merkmale D

- Austauschbarkeit: mit den wichtigsten Lieferanten
- Verschluss: ventil
- Kupplung: Radial Kugeln
- Werkstoff: Stahl
- Ausführung: Zn-Fe (Cr III)
- Gewinde: BSP - NPT
- Standard-Dichtungen: NBR
- Betriebstemperatur: -25 °C +100 °C
- Dichtungen nach Wahl: FKM, FFKM, EPDM, usw.
- Betriebsdruck: 100-400 bar
- Kuppeln unter Druck: nicht möglich

Caracteristiques techniques F

- Intercangeabilité: avec les principaux producteurs
- Obturation: clapet
- Accrochage: billes radiales
- Matériel: acier
- Traitement: Zn-Fe (Cr III)
- Taraudage: BSP - NPT
- Joints standard: NBR
- Température de service: -25 °C +100 °C
- Joints facultatifs: FKM, FFKM, EPDM, ect.
- Pression de service: 100-400 bar
- Connexion sous pression: pas possible

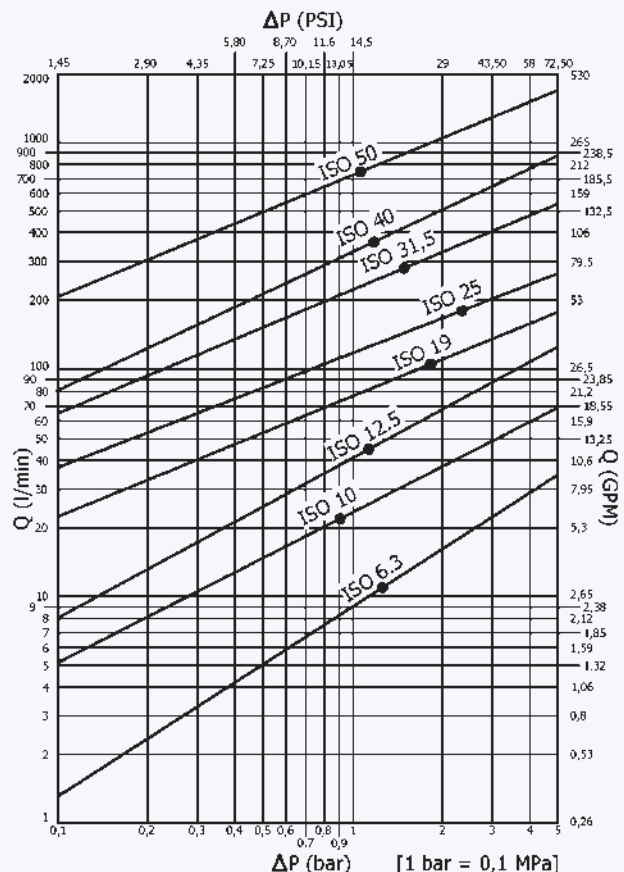

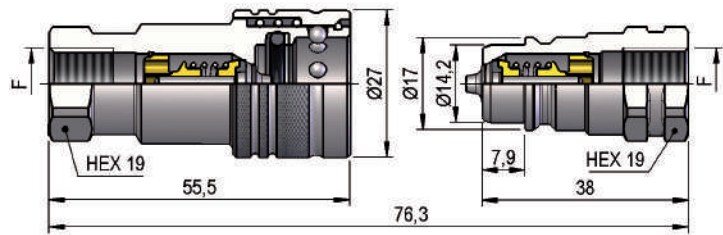
PDV1 DN06 - BG 1 - ISO 6.3

F	STANDARD	FEMMINA - FEMALE - MUFFE - FEMELLE			MASCHIO - MALE - STECKER - MALE		
		COD. F	Weight (g)	Packaging (pcs.)	COD. M	Weight (g)	Packaging (pcs.)
BSP 1/4"	DIN 3852-2-X	PDV1.0606.002	118	100	PDV1.0606.003	46	300
NPT 1/4"	ANSI B1.20.3	PDV1.0606.012	119	100	PDV1.0606.013	47	300

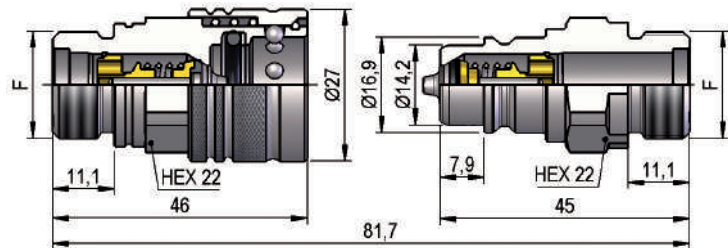

F	STANDARD	FEMMINA - FEMALE - MUFFE - FEMELLE			MASCHIO - MALE - STECKER - MALE		
		COD. F	Weight (g)	Packaging (pcs.)	COD. M	Weight (g)	Packaging (pcs.)
3/4"-16 UNF-2A	SAE J1926-3	PDV1.0619.302	100	100	PDV1.0619.303	65	300

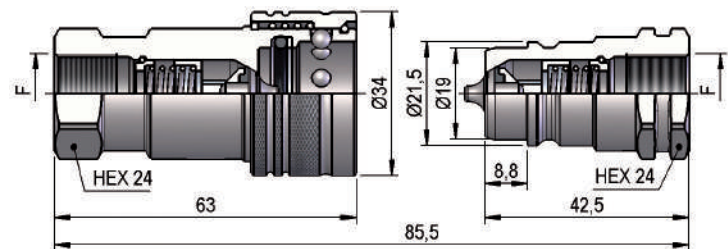
PDV1 DN10 - BG 2 - ISO 10

F	STANDARD	FEMMINA - FEMALE - MUFFE - FEMELLE			MASCHIO - MALE - STECKER - MALE		
		COD. F	Weight (g)	Packaging (pcs.)	COD. M	Weight (g)	Packaging (pcs.)
BSP 3/8"	DIN 3852-2-X	PDV1.1010.002	200	56	PDV1.1010.003	80	200
NPT 3/8"	ANSI B1.20.3	PDV1.1010.012	201	56	PDV1.1010.013	81	200

PDV1 DN13 - BG 3 - ISO 12.5

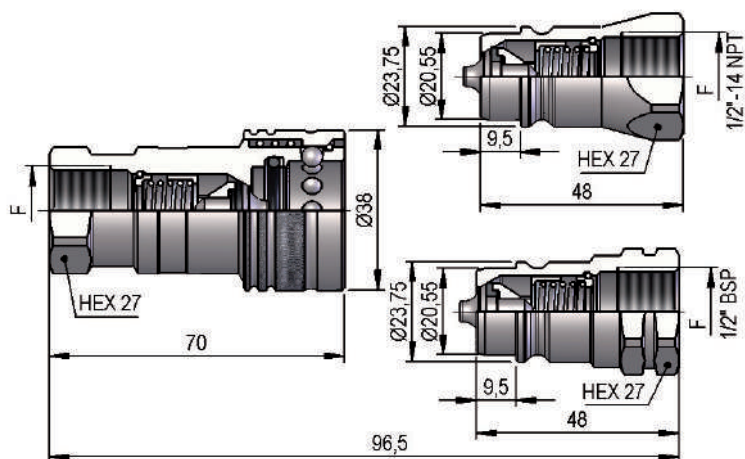

F	STANDARD	FEMMINA - FEMALE - MUFFE - FEMELLE			MASCHIO - MALE - STECKER - MALE		
		COD. F	Weight (g)	Packaging (pcs.)	COD. M	Weight (g)	Packaging (pcs.)
BSP 1/2"	DIN 3852-2-X	PAV1.1313.002	268	50	PAV1.1313.003	97	200
NPT 1/2"	ANSI B1.20.3	PAV1.1313.012	269	50	PAV1.1313.013	98	200

PDV1 DN20 - BG 4 - ISO 19

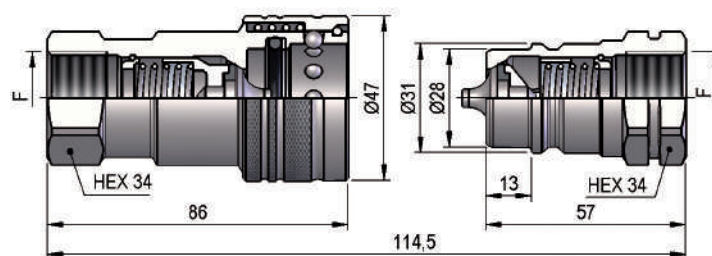

F	STANDARD	FEMMINA - FEMALE - MUFFE - FEMELLE			MASCHIO - MALE - STECKER - MALE		
		COD. F	Weight (g)	Packaging (pcs.)	COD. M	Weight (g)	Packaging (pcs.)
BSP 3/4"	DIN 3852-2-X	PDV1.2019.002	473	28	PDV1.2019.003	183	45
NPT 3/4"	ANSI B1.20.3	PDV1.2019.012	478	28	PDV1.2019.013	188	45

PDV1 DN25 - BG 5 - ISO 25

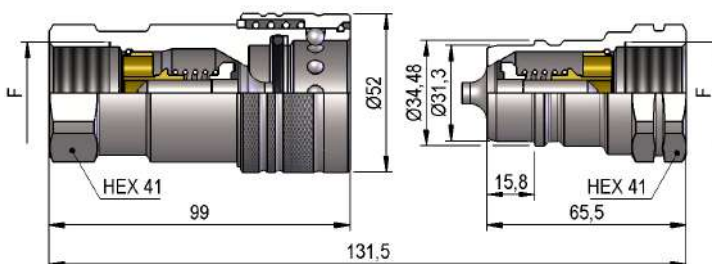

F	STANDARD	FEMMINA - FEMALE - MUFFE - FEMELLE			MASCHIO - MALE - STECKER - MALE		
		COD. F	Weight (g)	Packaging (pcs.)	COD. M	Weight (g)	Packaging (pcs.)
BSP 1"	DIN 3852-2-X	PDV1.2525.002	736	20	PDV1.2525.003	282	30
NPT 1"	ANSI B1.20.3	PDV1.2525.012	743	20	PDV1.2525.013	289	30

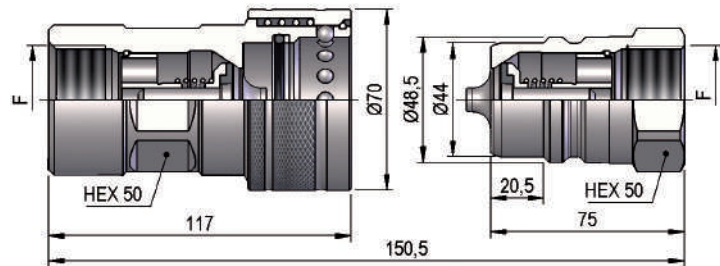
PDV1 DN30 - BG 6 - ISO 31.5

F	STANDARD	FEMMINA - FEMALE - MUFFE - FEMELLE			MASCIO - MALE - STECKER - MALE		
		COD. F	Weight (g)	Packaging (pcs.)	COD. M	Weight (g)	Packaging (pcs.)
BSP 1"¼	DIN 3852-2-X	PDV1.3031.002	1520	12	PDV1.3031.003	556	20
NPT 1"¼	ANSI B1.20.3	PDV1.3031.012	1537	12	PDV1.3031.013	573	20
RC 1"¼	EN 10226	PDV1.3031.042	1537	12	PDV1.3031.043	573	20

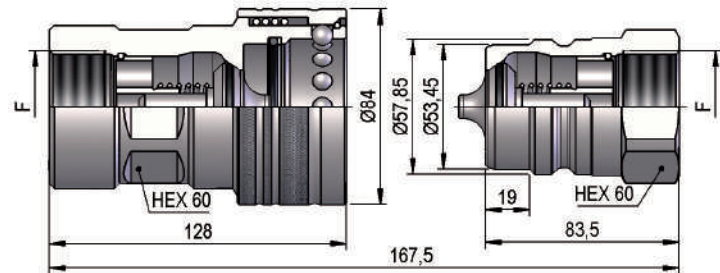
PDV1 DN39 - BG 7 - ISO 40

F	STANDARD	FEMMINA - FEMALE - MUFFE - FEMELLE			MASCIO - MALE - STECKER - MALE		
		COD. F	Weight (g)	Packaging (pcs.)	COD. M	Weight (g)	Packaging (pcs.)
BSP 1"½	DIN 3852-2-X	PDV1.3939.002	2472	8	PDV1.3939.003	936	12
NPT 1"½	ANSI B1.20.3	PDV1.3939.012	2491	8	PDV1.3939.013	955	12
RC 1"½	EN 10226	PDV1.3939.042	2491	8	PDV1.3939.043	955	12

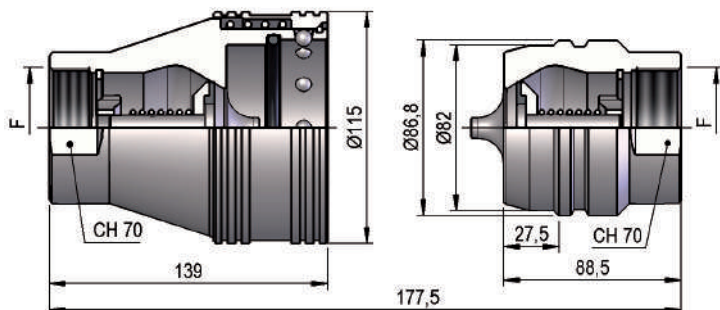
PDV1 DN50 - BG 8 - ISO 50

F	STANDARD	FEMMINA - FEMALE - MUFFE - FEMELLE			MASCIO - MALE - STECKER - MALE		
		COD. F	Weight (g)	Packaging (pcs.)	COD. M	Weight (g)	Packaging (pcs.)
BSP 2"	DIN 3852-2-X	PDV1.5051.002	4010	5	PDV1.5051.003	1892	8
NPT 2"	ANSI B1.20.3	PDV1.5051.012	4020	5	PDV1.5051.013	1900	8
RC 2"	EN 10226	PDV1.5051.042	4020	5	PDV1.5051.043	1900	8

PLASTIC CAPS

NOMINAL SIZE			FEMALE DUST PLUG					MALE DUST CAP					COLOR	MATERIAL
DNP	BG	ISO	COD. F	Dimensions			Weight (g)	COD. M	Dimensions			Weight (g)		
				D	L	D1			D	L	D1			
06	1	6.3	SPDV.06002	25	204	19.5	13	SPDV.06003	22	204	19.5	15	●	PVC
10	2	10	SPDV.10002	31	207	24.5	15	SPDV.10003	26	205	24.5	18	●	PVC
10	2	10	SPDV.10032	31	207	24.5	15	SPDV.10033	26	205	24.5	18	●	PVC
10	2	10	SPDV.10042	31	207	24.5	15	SPDV.10043	26	205	24.5	18	●	PVC
13	3	12.5	SPAV.13002	35	250	26	20	SPAV.13003	29	250	26	21	●	PVC
13	3	12.5	SPAV.13012	35	250	26	20	SPAV.13013	29	250	26	21	●	PVC
13	3	12.5	SPAV.13022	35	250	26	20	SPAV.13023	29	250	26	21	●	PVC
13	3	12.5	SPAV.13032	35	250	26	20	SPAV.13033	29	250	26	21	●	PVC
13	3	12.5	SPAV.13042	35	250	26	20	SPAV.13043	29	250	26	21	○	PVC
13	3	12.5	SPAV.13052	35	250	26	20	SPAV.13053	29	250	26	21	●	PVC
13	3	12.5	SPAV.13062	35	250	26	20	SPAV.13063	29	250	26	21	●	PVC
20	4	19	SPDV.20002	44	270	33	38	SPDV.20003	37	270	33	43	●	PVC
20	4	19	SPDV.20032	44	270	33	38	SPDV.20033	37	270	33	43	●	PVC
25	5	25	SPDV.25002	50	290	39	45	SPDV.25003	41	290	39	56	●	PVC

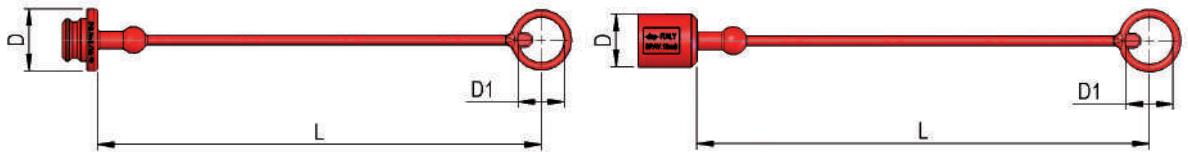

METAL CAPS

NOMINAL SIZE			FEMALE DUST PLUG					MALE DUST CAP					MATERIAL
DNP	BG	ISO	COD. F	Dimensions			Weight (g)	COD. M	Dimensions			Weight (g)	
				D	L	D1			D	L	D1		
13	3	12.5	SPAV.13202	38	205	32	51	SPAV.13203	38	205	32	70	Aluminum
30	6	31.5	SPAV.30202	70	275	47	120	SPDV.30203	63	275	47	215	Aluminum
39	7	40	SPAV.39202	83	275	47	170	SPDV.39203	78	275	47	355	Aluminum

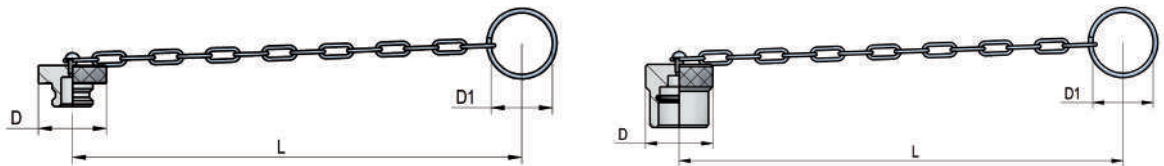

SPARE PARTS

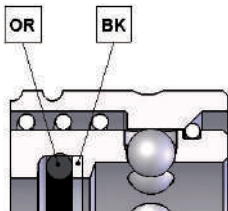

NOMINAL SIZE			FEMALE GASKET	
DNP	BG	ISO	OR (NBR*)	BK (PTFE)
06	1	6.3	PDV.006.120	PDV.006.130
10	2	10	PDV.010.120	PDV.010.130
13	3	12.5	PAV.013.120	PAV.013.130
20	4	19	PDV.019.120	PVV.019.130
25	5	25	PDV.025.120	PDV.025.130
30	6	31.5	PDV.030.120	PDV.030.130
39	7	40	PDV.039.120	PDV.039.130
50	8	50	PDV.050.120	-

*AL CODICE DELLA GUARNIZIONE IN NBR AGGIUNGERE 'E' PER EPDM O 'V' PER VITON

*TO THE NBR GASKET CODE ADD 'E' FOR EPDM OR 'V' FOR VITON

*ZU DER ARTIKELNR. DER NBR DICHTUNG GEBEN SIE 'E' FUER EPDM ODER 'V' FUER VITON AN

*AU CODE DU JOINT EN NBR JOINDRE 'E' POUR EPDM OU 'V' POUR VITON