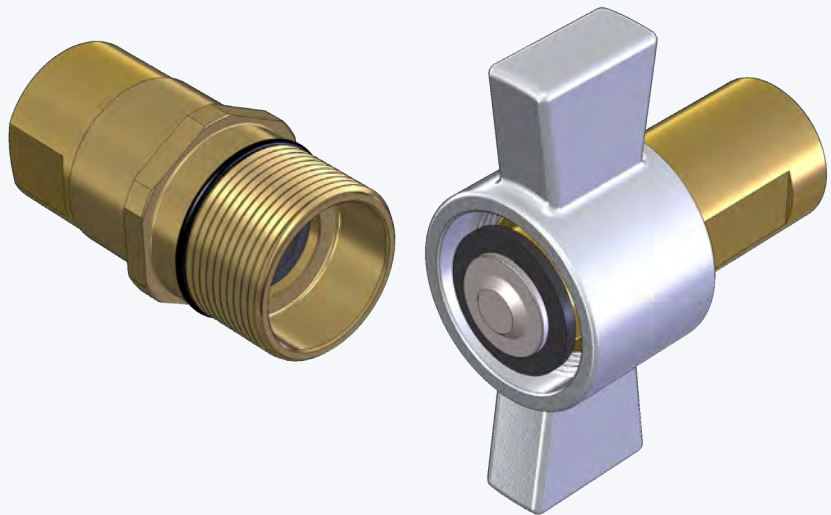

SCREW/WING NUT

GHIERA A FARFALLA/OTTONE
WING NUT/BRASS
FLÜGELMUTTERHÜLSE/MESSING
ECROU PAPILLON/LAITON

Caratteristiche tecniche

- Intercambiabilità: Parker/Snap-Tite 78
- Occlusione: faccia piana
- Aggancio: a vite
- Materiale: ottone e acciaio
- Finitura acciaio: Zn-Fe (Cr III)
- Filettature: NPT
- Guarnizioni standard: NBR
- Temperatura d'esercizio: -25 °C +100 °C
- Guarnizioni opzionali: FKM, EPDM o altro
- Pressioni di esercizio: 170-210 bar
- Connessione in pressione: non consigliata

Technical data

- Interchange: Parker/Snap-Tite 78
- Occlusion: flat face
- Locking: screw
- Material: brass and steel
- Steel finishing: Zn-Fe (Cr III)
- Threads: NPT
- Standard seals: NBR
- Working temperature: -25 °C +100 °C
- Optional seals: FKM, EPDM or more
- Working pressure: 170-210 bar
- Connection under pressure: not suggested

Nominal size				Max working pressure	Rated flow	Max flow rate	Min burst pressure			Fluid spillage
DNP	BG	ISO	mm				Male	Female	Coupled	
20	4	19	11.7	21	106	220	58	46	116	0.15
25	5	25	15.7	21	190	260	72	37	88	0.40
30	6	31.5	22.7	19	260	400	57	43	52	0.65
39	7	40	26.2	17	380	600	35	43	50	0.85

1 MPa = 145.04 psi • 1 l = 0.264 gal

Technische Merkmale

- Austauschbarkeit: Parker/Snap-Tite 78
- Verschluss: flachdichtend
- Kupplung: Schraubweise
- Werkstoff: Messing und Stahl
- Stahl Ausführung: Zn-Fe (Cr III)
- Gewinde: NPT
- Standard-Dichtungen: NBR
- Betriebstemperatur: -25 °C +100 °C
- Dichtungen nach Wahl: FKM, EPDM, usw.
- Betriebsdruck: 170-210 bar
- Kuppeln unter Druck: nicht empfohlen

Caracteristiques techniques

- Intercambiabilité: Parker/Snap-Tite 78
- Obturation: clapet plat
- Accrochage: a vissé
- Matériel: laiton et acier
- Traitement acier: Zn-Fe (Cr III)
- Taradage: NPT
- Joints standard: NBR
- Température de service: -25 °C +100 °C
- Joints facultatifs: FKM, EPDM, ect.
- Pression de service: 170-210 bar
- Connexion sous pression: non conseillée

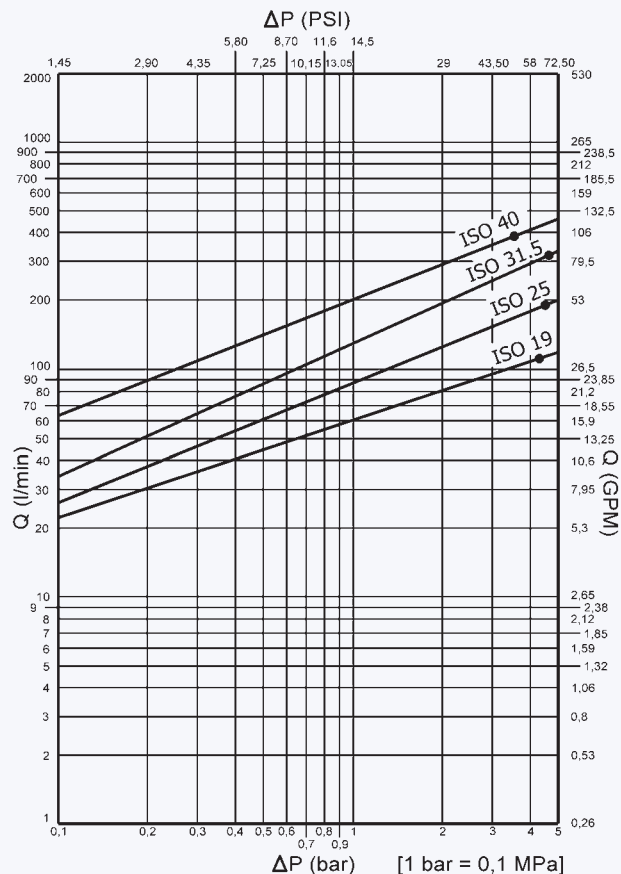

VVF1 DN20 - BG 4 - ISO 19

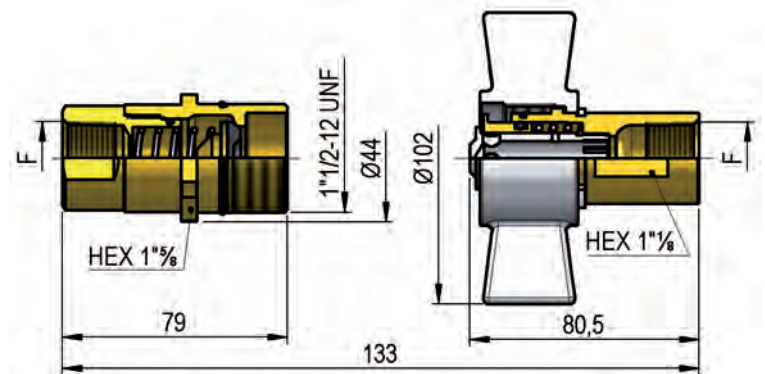

F	STANDARD	FEMMINA - FEMALE - MUFFE - FEMELLE			MASCIO - MALE - STECKER - MALE		
		COD. F	Weight (g)	Packaging (pcs.)	COD. M	Weight (g)	Packaging (pcs.)
NPT 1/2"	ANSI B1.20.3	VFF1.2013.012	430	33	VFF1.2013.013	635	16
NPT 3/4"	ANSI B1.20.3	VFF1.2019.012	395	33	VFF1.2019.013	602	16

VVF1 DN25 - BG 5 - ISO 25

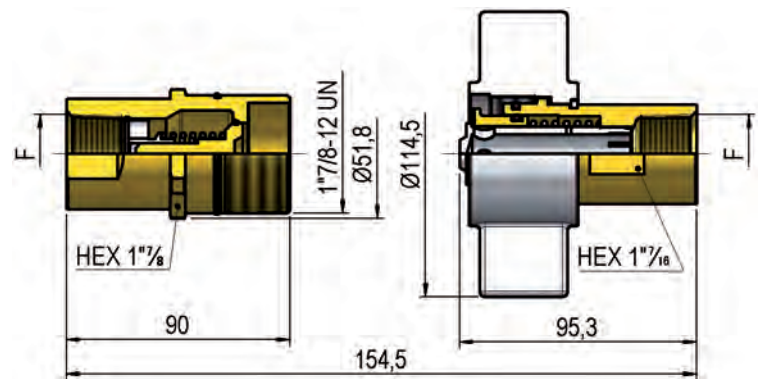

F	STANDARD	FEMMINA - FEMALE - MUFFE - FEMELLE			MASCIO - MALE - STECKER - MALE		
		COD. F	Weight (g)	Packaging (pcs.)	COD. M	Weight (g)	Packaging (pcs.)
NPT 1"	ANSI B1.20.3	VFF1.2525.012	633	21	VFF1.2525.013	1040	12

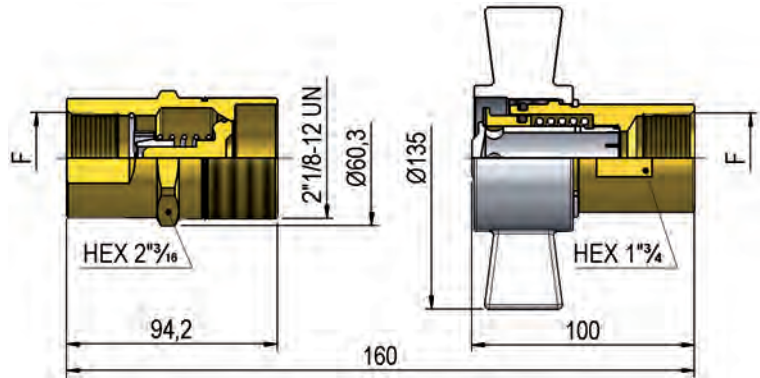
VFF1 DN30 - BG 6 - ISO 31.5

F	STANDARD	FEMMINA - FEMALE - MUFFE - FEMELLE			MASCIO - MALE - STECKER - MALE		
		COD. F	Weight (g)	Packaging (pcs.)	COD. M	Weight (g)	Packaging (pcs.)
NPT 1"¼	ANSI B1.20.3	VFF1.3031.012	765	18	VFF1.3031.013	1255	9

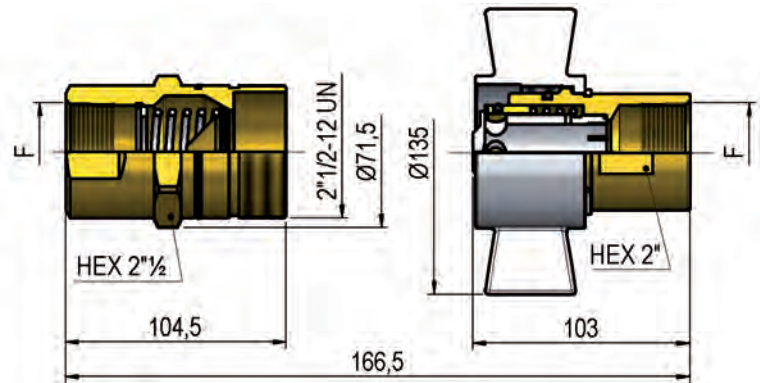
VFF1 DN39 - BG 7 - ISO 40

F	STANDARD	FEMMINA - FEMALE - MUFFE - FEMELLE			MASCIO - MALE - STECKER - MALE		
		COD. F	Weight (g)	Packaging (pcs.)	COD. M	Weight (g)	Packaging (pcs.)
NPT 1"½	ANSI B1.20.3	VFF1.3939.012	1160	8	VFF1.3939.013	1550	8

METAL CAPS

NOMINAL SIZE				FEMALE DUST PLUG				MALE DUST CAP				MATERIAL	
DNP	BG	ISO	COD. F	Dimensions			Weight (g)	COD. M	Dimensions			Weight (g)	
				D	L	D1			D	L	D1		
20	4	19	SVFF.20402	41	210	30	73	SVFF.20403	40	210	30	107	Brass
25	5	25	SVFF.25402	53	270	41	147	SVFF.25403	48	270	41	185	Brass
30	6	31.5	SVFF.30402	62	280	48	243	SVFF.30403	56	280	48	248	Brass
39	7	40	SVFF.39402	69	280	48	287	SVFF.39403	63	280	48	367	Brass

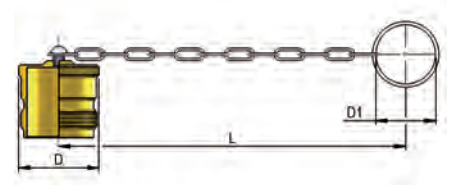
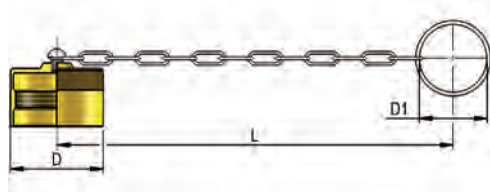

SPARE PARTS

NOMINAL SIZE			FEMALE GASKET	MALE GASKET
DNP	BG	ISO	OR-E (NBR)	OR-I (FKM)
20	4	19	VFF.019.121	PLT.325.030 V
25	5	25	VFF.025.121	VFF.025.120 V
30	6	31.5	VFF.030.121	PTV.025.120 V
39	7	40	VFF.039.121	VFF.039.120 V

